

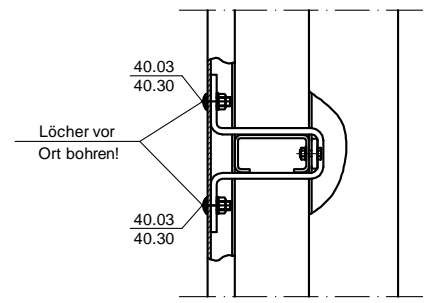

1) Verankerung der hinteren Verstärkung mit Verankerungsbügeln an den letzten 3 Pfosten (siehe Detail X)

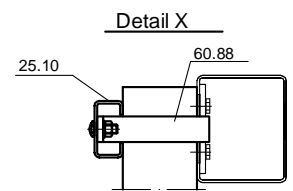
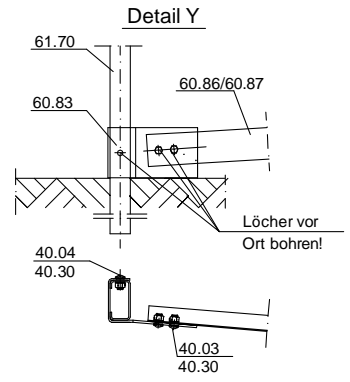
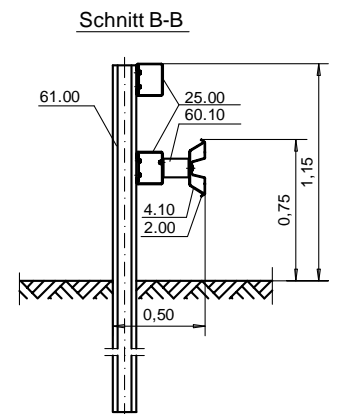
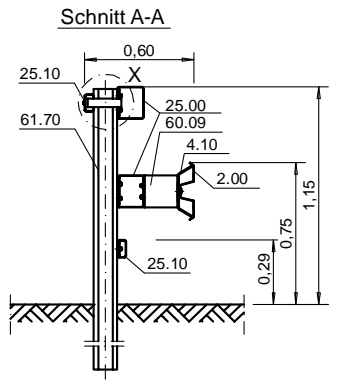
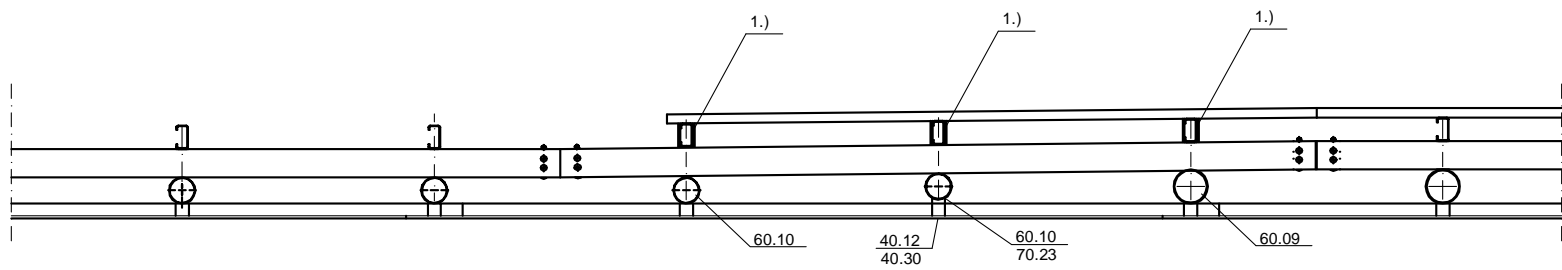

Die Konstruktion ist patentrechtlich geschützt.

Verschraubung siehe Zeichnung Nr. B1.1-202 und B1.1-203

Profil A sinngemäß ausführen.

S3.1-316	Zchg. Nr. S3.1-316	Übergang SUPER-RAIL Plus auf SUPER-RAIL	
	Stand: 03/10		
Gütegemeinschaft Stahlschutzplanken e.V.			